



IMPORTANT!

Read these instructions carefully before use and keep them for further reference. Your child's safety may be affected if you do not follow these instructions.

Please read this User Guide carefully BEFORE trying to use your stroller

⚠ WARNING – A CHILD'S SAFETY IS YOUR RESPONSIBILITY

Looking after your stroller

The stroller and its cover have been carefully designed, manufactured and tested to high safety standards.

Regularly inspect and maintain your stroller to ensure freedom of movement of the locking devices and security of components. To prolong the life of your stroller, keep it clean and do not leave it in direct sunlight for extended periods of time.

Helpful hints

Regularly clean and lubricate the front swivel and wheel units as dirty or dry units can have an adverse effect on manoeuvrability and steering.

When using the stroller on the beach, clean it completely afterwards to remove all the sand and salt from the mechanisms and wheel assemblies.

This stroller is not waterproof and is supplied with a rain cover. Under certain climate conditions the covers and trims may be affected by mould and mildew. To help prevent this occurring, do not fold or store this stroller if it is wet or damp and always use the rain cover when necessary. Always store in a well ventilated area.

Cleaning the cover

The hood, seat covers and trims may be cleaned using warm water with household soap or mild detergent. Allow it to dry fully, away from direct sunlight.

DO NOT dry clean or use bleach or any other aggressive cleaning agents.

To maintain the safety of your stroller, seek prompt repairs for bent, torn or broken parts. Use only those parts and accessories approved by Britax. Replacement parts and accessories are available from your Britax stockist or contact Britax Customer Service

Department on 01264 386034. This product is not intended for commercial use.

Guarantee

Please be aware that faults caused by failing to follow the maintenance advice above are not covered by the product's warranty.

All Britax products are carefully designed, manufactured and tested. However, should this product prove faulty within six months of purchase due to a materials or manufacturing fault please return it to the original place of purchase. We will then, at our discretion, repair it free of charge.

For guarantee purposes proof of purchase will be required. We recommend that you retain your receipt and attach it to this user guide. They should be kept in a safe place.

Britax does not accept liability for damage arising from abuse, misuse or negligence. This guarantee is not transferable and therefore does not apply to second-hand products.

Your statutory rights are not affected by this guarantee.

Register your stroller on-line now

It's quick and easy, and we can update you with news, advice and safety information. Visit www.britax.eu/registration



Carry Cot⁺ (V Type) also available.

WARNING – Ensure that all locking devices are engaged before use.

WARNING – Check that the seat unit attachment devices are correctly engaged before use.

WARNING – Children must be harnessed at all times.

WARNING – Overloading, incorrect folding and the use of non-approved accessories may damage or break this stroller and make it unstable for use.

WARNING – Regularly inspect the stroller to ensure all parts are in full working order.

WARNING – Any load attached to the handle affects the stability of the pushchair.

WARNING – This seat unit is not suitable for children under 6 months.

WARNING – Always use the crotch strap in combination with the waist belt.

WARNING – This product is not suitable for running or skating.

WARNING – It may be dangerous to leave your child unattended.

DO NOT leave or place your child in a position where they are exposed to the sun. The canopy or hood on this product will not give your child total protection from the harmful rays of the sun.

DO NOT allow the stroller to remain wet for prolonged periods of time. If it does get wet, allow to dry unfolded at room temperature.

DO NOT place more than 4kg in the basket, or 1kg in the canopy pocket (if supplied).

DO NOT allow children to play with or adjust the stroller.

DO NOT carry more than one child on this stroller.

DO NOT lift the stroller by the bumper bar – it may disengage.

DO NOT use accessories that are not approved by Britax Excelsior Limited.

DO NOT use a PVC rain cover indoors, in a hot atmosphere or near a direct heat source - your child might overheat.

DO support the back of the stroller seat when reclining it.

DO if using an alternative harness, please ensure it conforms to an appropriate safety standard i.e. BS6684. 'D' ring attachments are found on each side of the stroller.

DO read the cleaning instructions for the cover.

DO ensure children are clear of moving parts and locking devices while making adjustments.

DO periodically check that any screws, nuts, bolts and other fastenings are fully tightened.

DO store the stroller in a safe place when not in use. Avoid placing heavy objects on top of it and do not store near direct heat sources, e.g. radiators, open bar fires or in direct sun light as the cover may fade.

ALWAYS remove the child from the stroller before going up or down stairs or escalators.

This stroller is designed and manufactured to comply to EN1888: 2005.

Britax Excelsior Limited

1 Churchill Way West
Andover
Hampshire SP10 3UW
United Kingdom

A Britax Childcare company

Customer Service Helpline: 01264 386034
Email: helpline@uk.britaxeurope.com
Switchboard: +44 (0) 1264 333343
Fax: +44 (0) 1264 334146

www.britax.eu

Introducing your new stroller

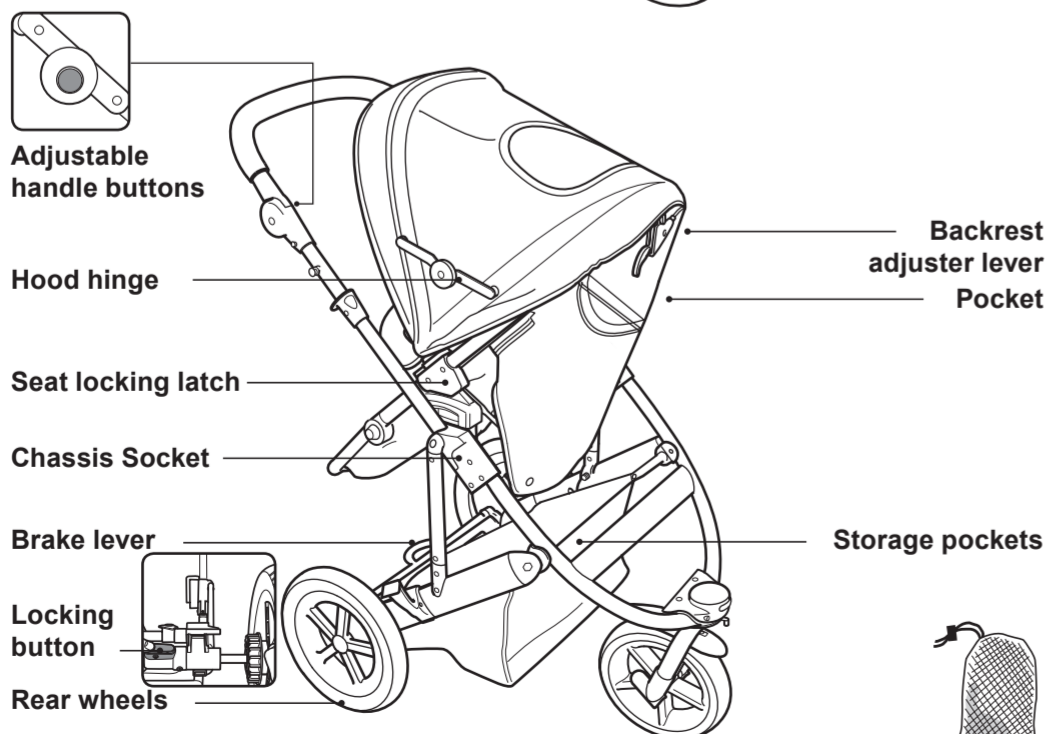
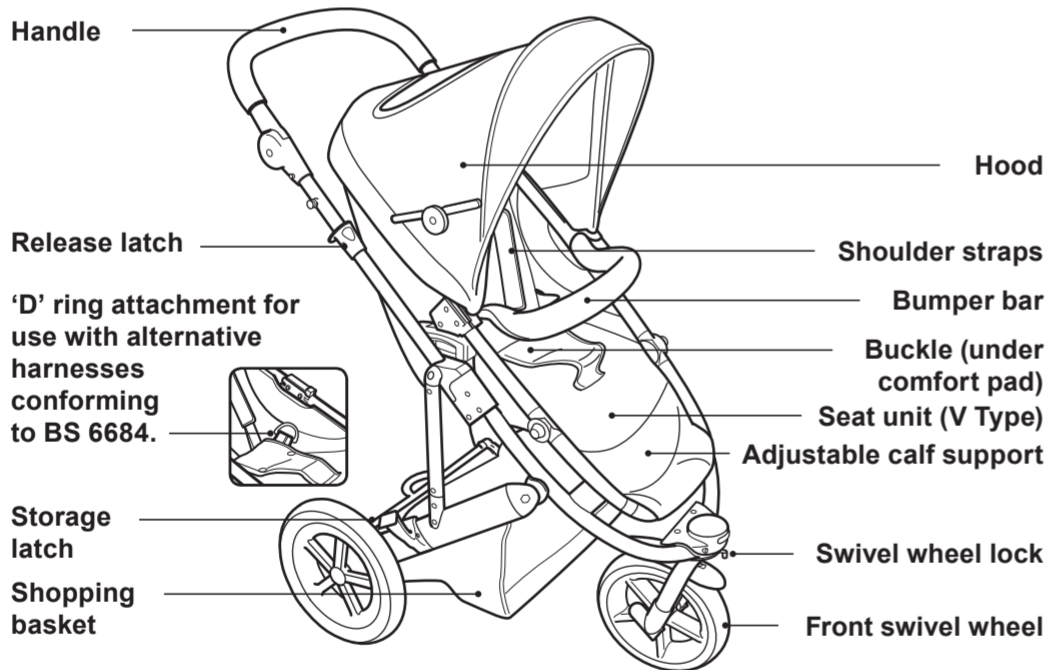

AZ0-041

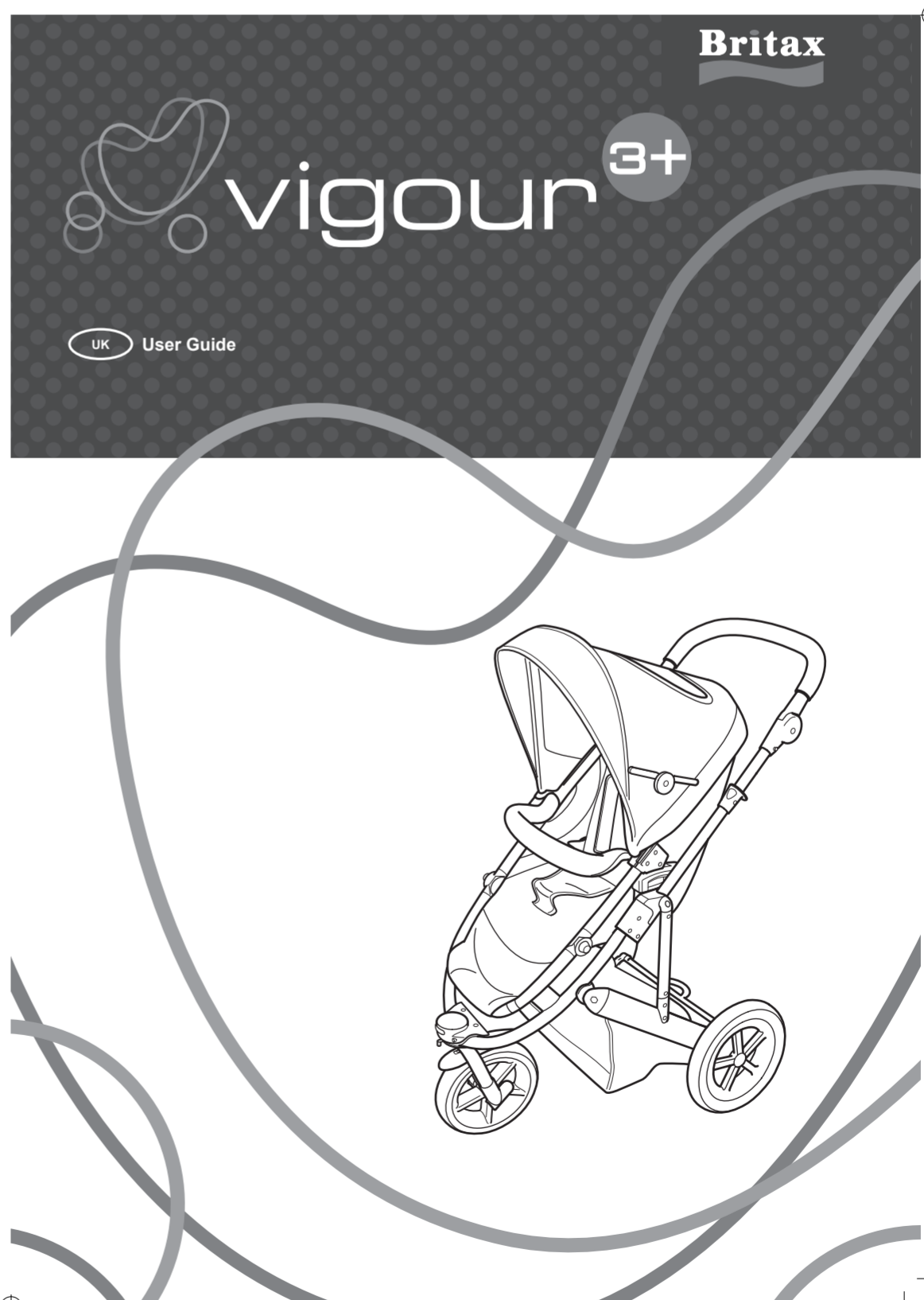

1 Assembling your chassis

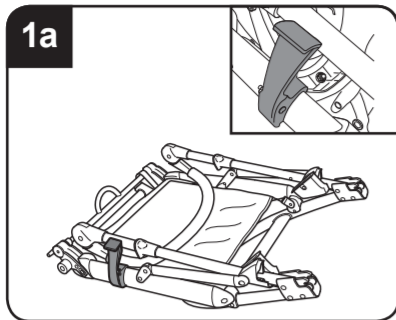

Release the storage latch (dia 1a).

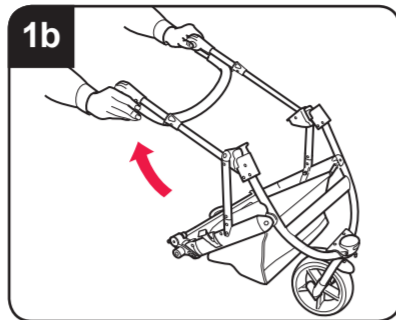

Hold the handle and lift upwards until the chassis is fully extended and clicks into position (dia 1b).

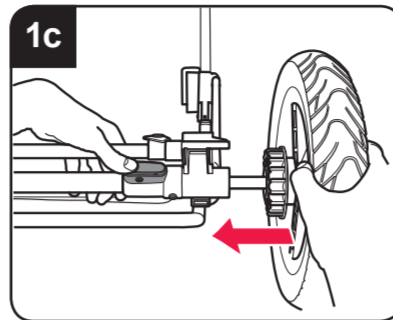

Push the rear wheel assembly into the rear wheel axle (dia 1c). Check the wheel is correctly fitted by trying to pull it out. Repeat this process for both wheels.

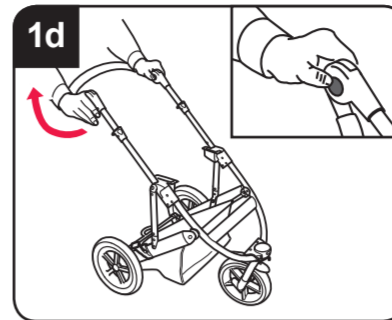

Adjust the handle to a comfortable height by simultaneously pressing the buttons on the inside of the handle – on both sides (dia 1d).
Check the chassis is ready for use by pressing down on the handle – the chassis should not collapse.
WARNING – Ensure that all locking devices are engaged before use.

2 Attaching your seat unit and using your stroller

(this vehicle is intended for children from 6 months and up to 15kgs) **IMPORTANT** - A V-Type seat unit must be used with this V-Type chassis

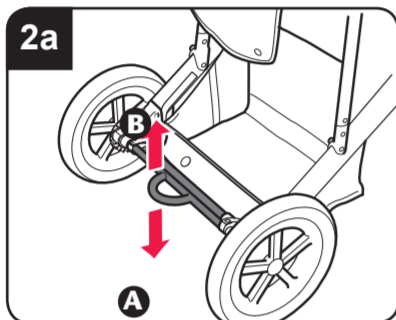

HANDY HINT – You may find it helpful to apply the brake when fitting the seat unit.

Push down on the brake lever to lock the brakes **A**. To release the brake lift brake lever **B** (dia 2a).

IMPORTANT – Always apply the brakes when you park the stroller.



IMPORTANT – Always remove your child from the seat unit prior to installation, removal or change of seat direction. The seat unit can be installed forward or rearward facing.

To install the seat unit, insert the seat locking latches into both chassis sockets (dia 2b).

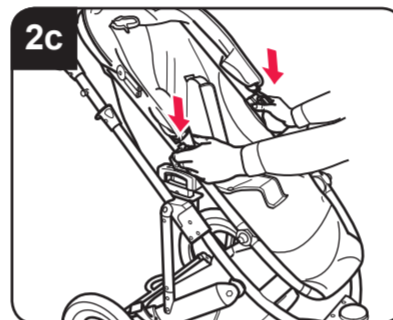

Push down on the seat until you hear an audible 'click' (dia 2c).

WARNING – Check that the seat unit attachment devices are correctly engaged before use by lifting the seat.

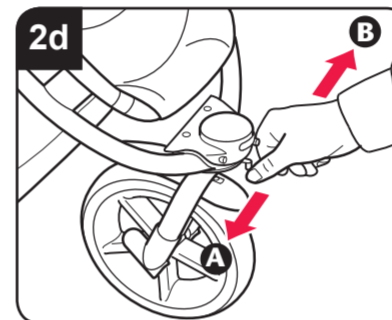

To lock the swivel wheel, push lock towards **A**. To unlock swivel wheel, push towards **B** (dia 2d).

HANDY HINT – The front wheel should be locked when used on uneven surfaces or mounting kerbs.

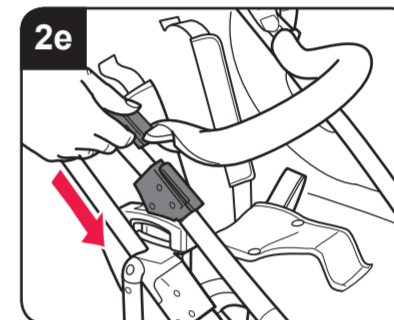

To attach the bumper bar (dia 2e), remove the hood (if fitted). Align the bumper bar mouldings with the fixings then slide both bumper bar mouldings onto the seat unit until fully engaged.

To remove the bumper bar, remove the hood (if fitted) then slide both bumper bar mouldings off the seat unit fixings.
WARNING! DO NOT lift the stroller by the bumper bar or hood. It may disengage or damage your product.

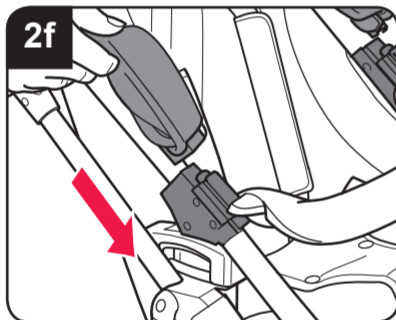

To fit the hood align with the fixings on the bumper bar and slide down (dia 2f) until fully engaged.

The hood can be fitted without the bumper bar by aligning with the fixings on the seat unit and sliding down until fully engaged.

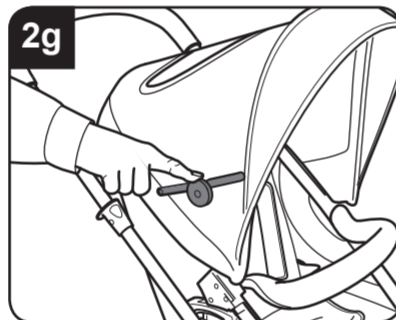

To open the hood, pull the front of the hood forward then push the hood hinges down on both sides (dia 2g).

To remove the hood, slide the hood off the fixings on the seat unit, or off the fixings on the bumper bar (if fitted).

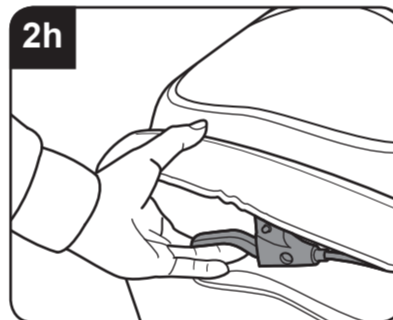

To adjust the backrest, squeeze the backrest adjuster lever at the top of the seat unit, then raise or lower the seat unit to the desired position (dia 2h).

IMPORTANT – Use the harness at all times.
IMPORTANT – Do not lift the stroller by the seat unit.

IMPORTANT – Support the back of the pushchair seat unit when adjusting the angle.

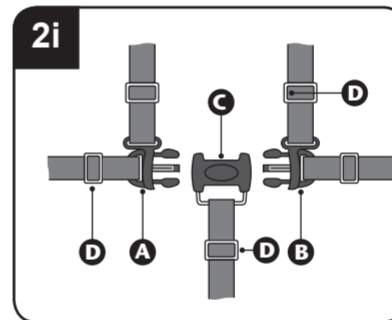

Unfasten the comfort pad to reveal the five-point harness. A five-point harness is provided to restrain your child (dia 2i). To secure the child in the harness, push buckle **A** and **B** into buckle housing **C** until the buckle prongs snap into position. Carefully adjust the harness by pulling the slider **D** until the desired fit is achieved in the waist belt, shoulder and crotch straps.

Always adjust the harness when changing the seating position of the child. To release the buckle, squeeze the top and bottom prongs **A**.

WARNING – Always use the crotch strap in combination with the waist belt.
WARNING – Fasten the harness when not in use to prevent it becoming trapped when folding the stroller.

3 Folding your stroller

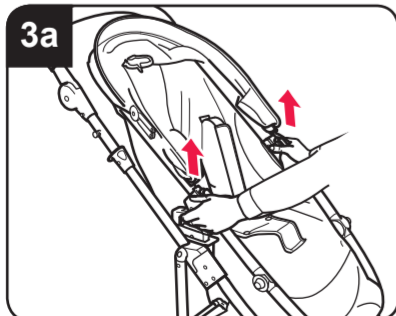

IMPORTANT – Always remove your child from the seat unit prior to installation, removal, change of seat direction or folding.

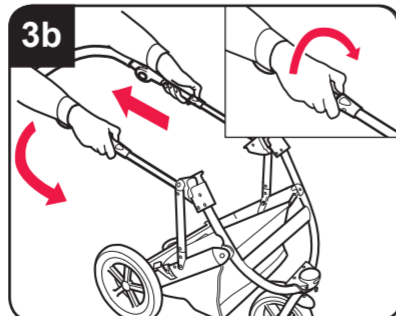

HANDY HINT – For a more compact storage, fold the handle down. Refer to (dia 1d) for instruction on operating handle adjustment.

Stand at the rear of the chassis, pull both release latches and twist the right hand one in the direction of the arrow marked on the release latch (dia 3b).

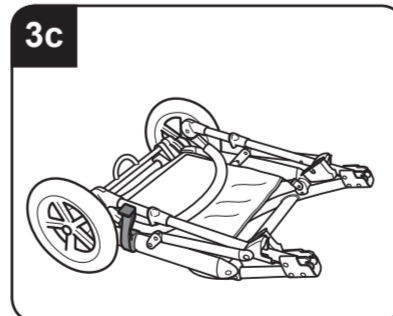

Push the handle down allowing the chassis to fold until it moves into the fully folded position. Ensure that the storage latch is closed (dia 3c).

HANDY HINT – The chassis may also be folded with the seat unit attached.

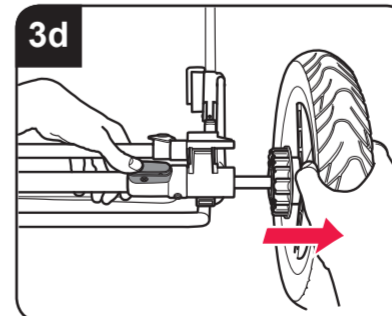

To remove the rear wheels, push the locking button and pull the corresponding rear wheel out (dia 3d).