



Freedom to play

# TP130, 131 & 132 Single, Double & Triple Giant Swing Frames

## INSTRUCTIONS FOR ASSEMBLY MAINTENANCE AND USE



**Important!**

These instructions must be followed for safe assembly and use. Please retain for future reference.

**Important!**

Vous devez suivre ces instructions pour que le montage et l'utilisation se fassent en toute sécurité. Veuillez conserver pour référence ultérieure.

**Importante!**

Per garantire sicurezza di montaggio ed uso, seguire queste istruzioni e conservarle per futuro riferimento.

**Importante!**

Debe seguirse estas instrucciones para un armado y uso seguros. Sírvase conservarlas para consultarlas en el futuro.

**Wichtig!**

Diese Anweisung ist für sicheren Aufbau und Gebrauch zu befolgen. Für künftigen Gebrauch aufbewahren.

## INSTRUCTIONS FOR ASSEMBLY, MAINTENANCE AND USE OF *tp* TOYS

Please read carefully and keep all enclosed information or future reference.

### 1. ASSEMBLY AND SAFETY INFORMATION

*tp* toys must be assembled by an adult. They must be erected exactly in accordance with the assembly instructions. Enlisting the aid of a helper will make assembly easier. We recommend that you place small parts on a tray, or something similar, to prevent the frustration and disappointment of mislaying them. Please take care during assembly as the manufacturing process can sometimes result in the occasional sharp edge and small pieces of waste metalwork. Should there be any missing parts, the toy must not be used until replacement parts have been fitted - the *tp* Customer Services line is +44 (0)1299 872804 (English Speaking).

### 2. SITING

Under no circumstances should any of our toys be positioned on hard surface such as concrete or asphalt, unless the ground under the toy plus the recommended freespace area is covered with a safety surface (please refer to diagram on page 16). Examples of suitable surfaces are grass, sand or a play surface intended for this use. *tp* toys should be sited on level ground.

### 3. USAGE

*tp* toys are designed and made for family outdoor domestic use only by children aged between 3 and 14 years, unless otherwise stated, and must not be used by anybody else. Misuse can result in injury.

### 4. SUPERVISION

Children should always be supervised while they are playing on *tp* toys and should be instructed not to use the toy in an inappropriate or hazardous manner. We recommend that they do not wear loose-fitting clothing or jewellery that may catch or snag during play. Children should not wear cycle helmets while playing on *tp* toys.

### 5. WEATHER CONDITIONS

Special care should be taken as weather conditions change. In particular, outdoor toys can become slippery in wet weather and tongues and lips can stick to metalwork at subzero temperatures. In warmer and sunnier weather, parts can become hot, and the temperature should be regularly checked during play, especially metal parts and slides. If there is any doubt over safety then the toys should not be used.

### 6. WATER PLAY

Many surfaces can become slippery during water play. Extra caution and supervision is required when combining water (e.g. paddling pools, aqua slides etc.) with other forms of outdoor play.

### 7. MAINTENANCE.

With all toys it is vital that the equipment is checked regularly and often by an adult. The complete toy should be checked at least once a month, and particular attention should be paid to connections and fastenings. If any parts exhibit signs of wear and tear, they may need to be replaced. Checks must be carried out at the beginning of the usage season as well as at regular intervals throughout the usage season. Check all nuts and bolts for tightness and tighten when required. Failure to do this may result in the product malfunctioning, and causing injury. Children must not be allowed to use the toy until properly installed and checked. Galvanised tubular products may require occasional maintenance. If surface rust appears it should be removed with either a wire brush or coarse sandpaper, and the area treated with a non-toxic paint.

### 8. SWING FRAMES

These must always be used with the stakes provided. We recommend that you concrete them in place (please refer to diagram on page 16). Never set the legs of a swing frame in concrete.

### 9. SWINGING TOYS

When fitting swinging toys it is vital that moving parts have no metal to metal contact. Children should be instructed not to pass in front of or behind moving items, not to twist or swing an empty swing seat, and not to get off a swinging toy when it is in motion. Please refer to freespace diagram on page 16.

### 10. ROPES

These ropes will degrade over time. When signs of degradation appear, the toy should be replaced.

### 11. TRAMPOLINES

We recommend the fitting of safety pads for all trampolines. *tp* trampolines are designed as toys and should not be used as gymnastic equipment, unless otherwise stated.

### 12. FIRE RISKS AND DISPOSAL

Never allow *tp* toys to be placed or used near a fire. When it becomes necessary to dispose of your equipment, remove all bolts and disassemble. Store out of the reach of children until it can be properly disposed of.

These instructions are issued in the interest of child safety, and we do ask you to follow our advice.

Made in England by: *tp* Activity Toys.

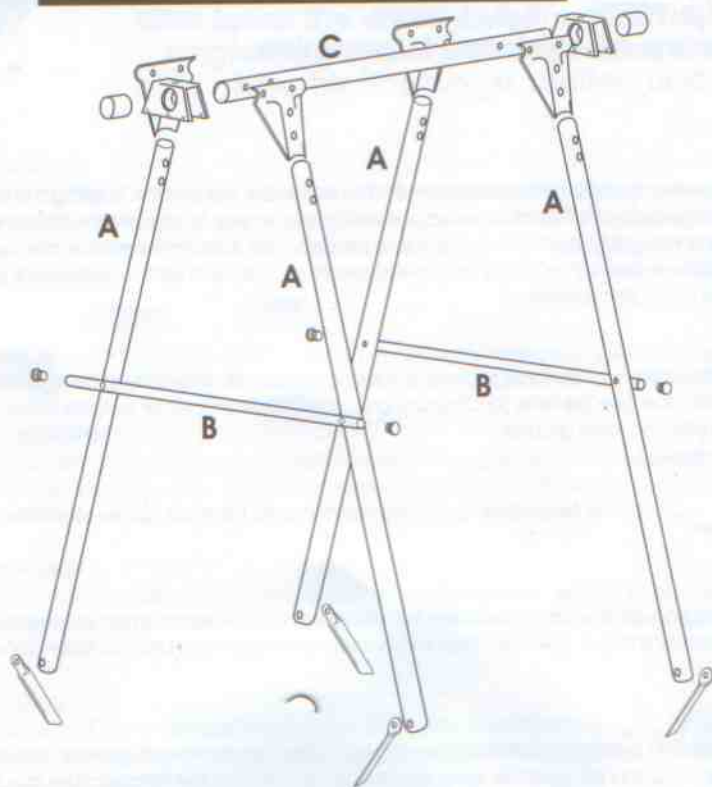

Contents - Please check

Contenu - Veuillez vérifier

Siete pregati di controllare il contenuto

Verifique el contenido

Inhalt - Bitte Überprüfen

Bolt Tightening Guide

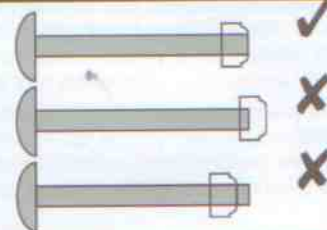

Tools

You will need:  
 Vous aurez besoin de:  
 Avrete bisogno:  
 Precisarà:  
 Sie brauchen:



MT 0008



MT 0007



MT 0006



PR 7669



2

PM 7445

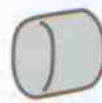

2

PR 5069



4

PR 7670  
(1A + 1B)

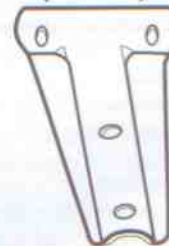

4

FA 5167  
60mm



4

FA 5168  
80mm



4

FA 5193  
40mm



2

FA 5180  
65mm



14

PM 7084



4

PM 5243



4

FA 5174



15

FA 5096



12

FA 5175



12

PM 9253



4

FA 5094



8



Dimensions in mm

# 3

## Single Giant Swing

globe inc.

Preparation

Préparation

Preparazione

Preparación

Vorbereitung

PR 7670  
(1A)



2

PR 7670  
(1B)

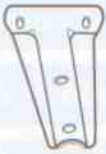

2

PR 7669



2

FA 5174



6

FA 5180  
65mm



6

TP 7445



2

PM 9253



2

FA 5096



2

MT 0006



1

### Swing Attachment Configurations *tp* 130 Single Giant Swing Frame



Position 1 One Duo Ride

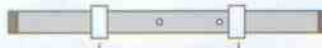

Position 2 One Single Seater



Position 3 One Duo Ride  
(Single Attachment)

### Single Giant Swing with Double Mount Accessory

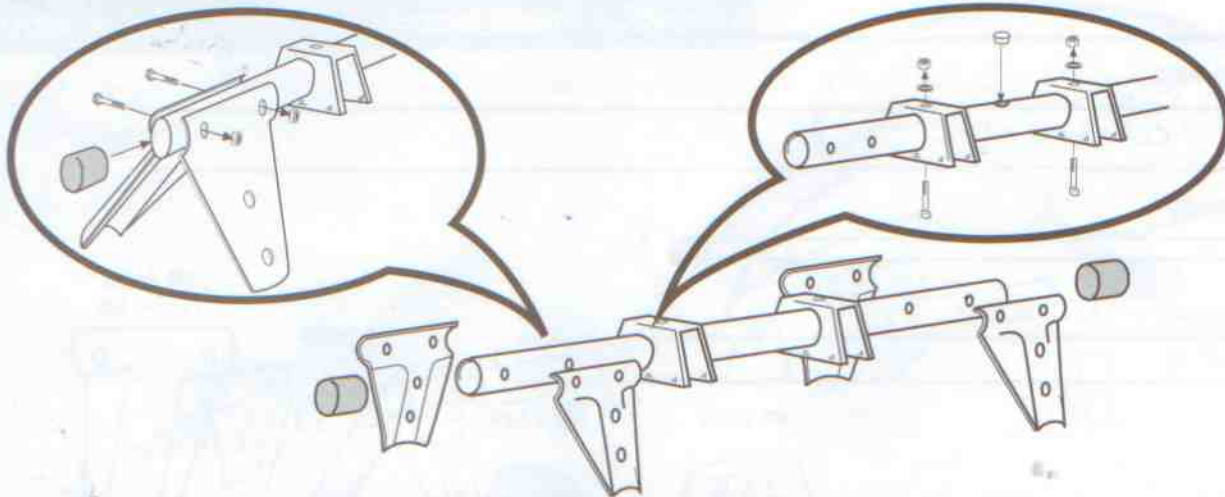

### Single Giant Swing with Central Mount Accessory

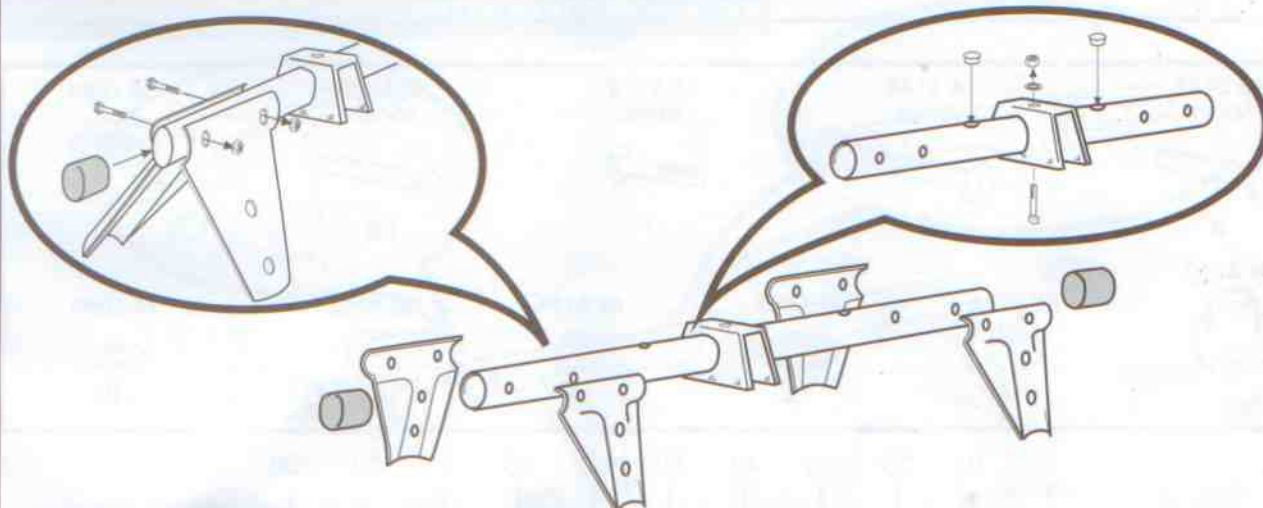

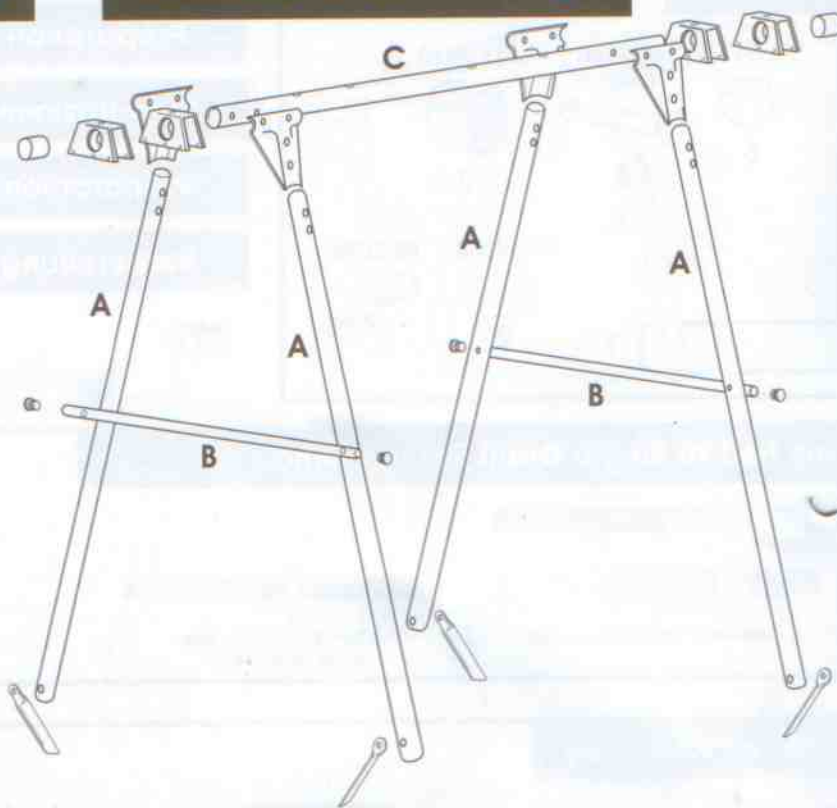

Contents - Please check

Contenu - Veuillez vérifier

Siete pregati di controllare il contenuto

Verifique el contenido

Inhalt - Bitte Überprüfen

Bolt Tightening Guide

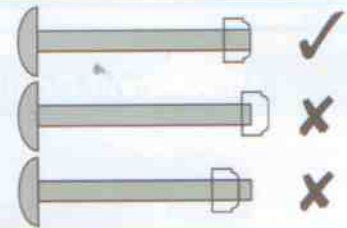

Tools

You will need:  
 Vous aurez besoin de:  
 Avrete bisogno:  
 Precisară:  
 Sie brauchen:



MT 0008



MT 0007

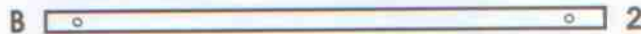

MT 0009



PR 7669



4

PM 7445



2

PR 5069



4

PR 7670  
(1A + 1B)

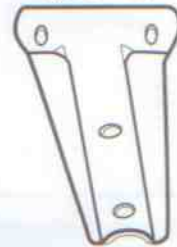

4

FA 5167  
60mm



4

FA 5168  
80mm



4

FA 5193  
40mm



4

FA 5180  
65mm



16

PM 7084



4

PM 5243



8

FA 5174



17

TP 5096



12

FA 5175



14

PM 9253



8

FA 5094



8

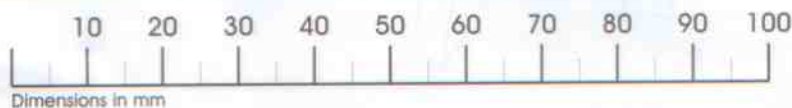

Dimensions in mm

# 5

## Double Giant Swing

مكونات التثبيت

Preparation

Préparation

Preparazione

Preparación

Vorbereitung

PR 7670  
(1A)

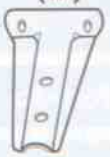

2

PR 7670  
(1B)



2

PR 7669



4

FA 5174



8

FA 5180  
65mm



8

PM 7445



2

PM 9253



8

FA 5096



4

MT 0009



C

1

### Swing Attachment Configurations *tp* 131 Double Giant Swing Frame



Position 1 One Duo Ride



Position 2 One Single Seater



Position 3 One Duo Ride (Single Attachment)



Position 3 One Duo Ride (Single Attachment)

### Double Giant Swing with Double Mount Accessory

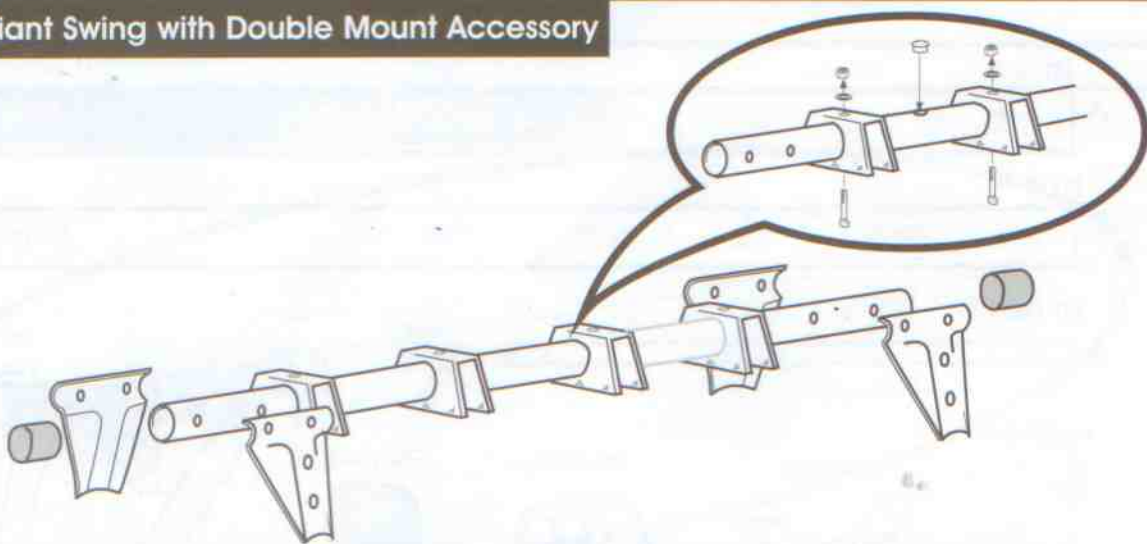

### Double Giant Swing with Central Mount Accessory

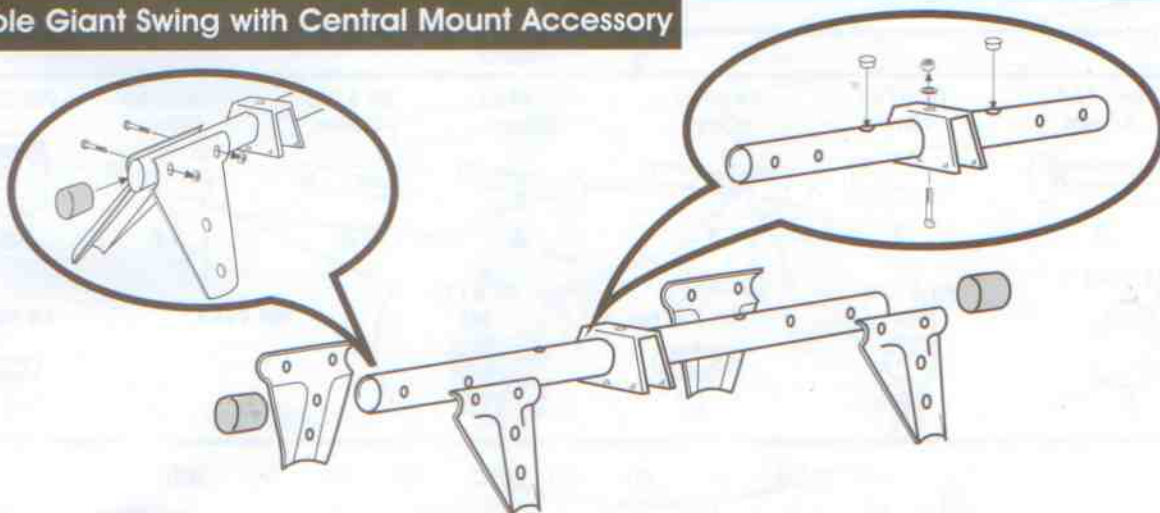

Contents - Please check

Contenu - Veuillez vérifier

Siete pregati di controllare il contenuto

Verifique el contenido

Inhalt - Bitte Überprüfen

Bolt Tightening Guide

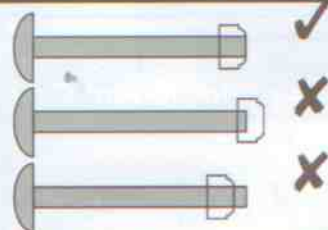

Tools

You will need:  
 Vous aurez besoin de:  
 Avrete bisogno:  
 Precisarã:  
 Sie brauchen:

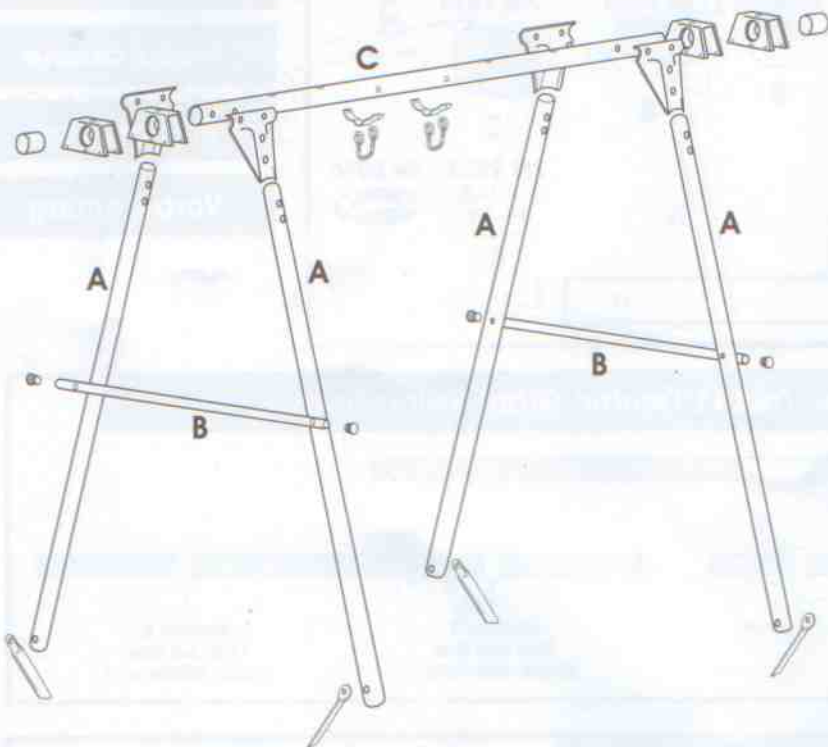

MT 0008



MT 0010



MT 0007



FA 5213



PR 5359

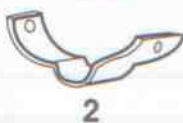

PR 7669

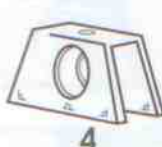

PM 7445



FA 5069



PR 7670  
(1A + 1B)



FA 5152  
45mm

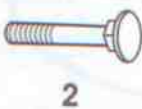

FA 5244  
45mm

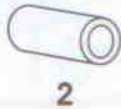

FA 5167  
60mm



FA 5168  
80mm



FA 5193  
40mm



FA 5180  
65mm

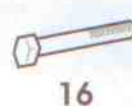

PM 7084



PM 5243



FA 5174  
M8



FA 5096



FA 5175  
M6



PM 9253



FA 5094



Dimensions in mm

# 7

## Triple Giant Swing

Preparation

Préparation

Preparazione

Preparación

Vorbereitung

PR 7670  
(1A)



2

PR 7670  
(1B)



2

PR 7669



4

FA 5174



8

FA 5180  
65mm



8

PM 7445



2

PM 9253



8

FA 5096



4

MT 0010

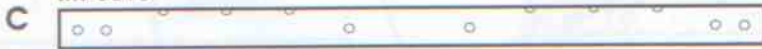

1

### Swing Attachment Configurations *fp 132 Triple Giant Swing Frame*



### Triple Giant Swing with Mount Accessories

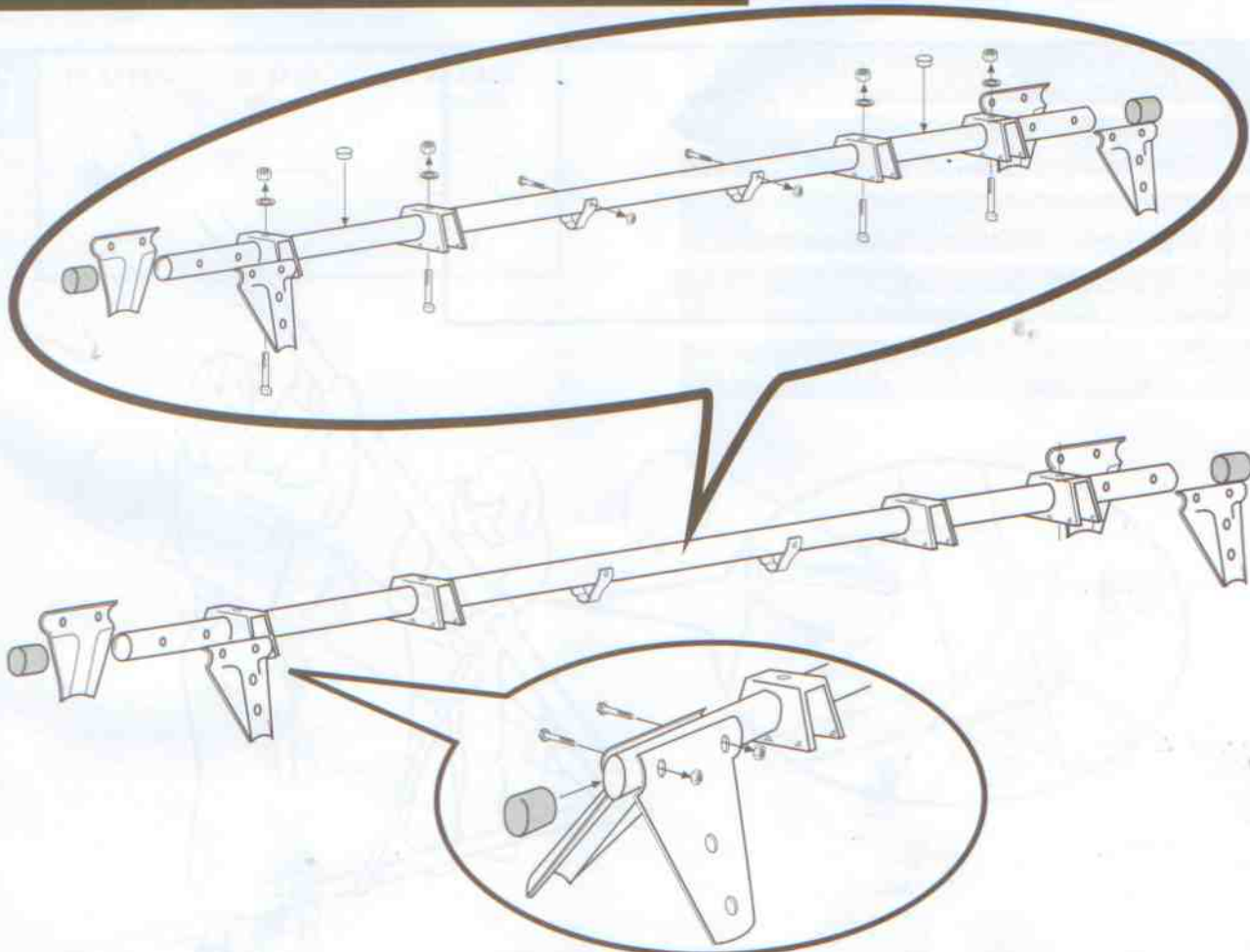

**8**FA 5180  
65mm

8

FA 5096



8

FA 5174  
M8

8

TM 0008



A

4

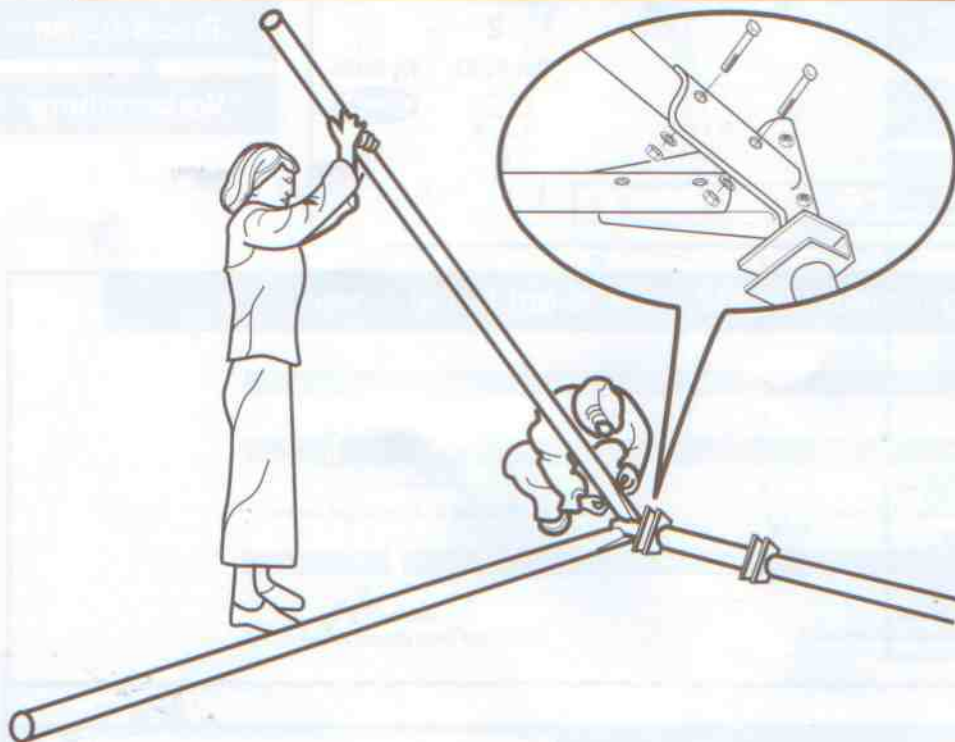
**Assembly****Montage****Montaggio****Montaje****Montage**

We recommend that all fastenings are tightened only fingertight until the product is completely assembled.

Tant que le montage n'est pas entièrement terminé, nous recommandons de serrer les fixations à la main seulement.

Si raccomanda di serrare solo con le dita i dispositivi di fissaggio prima del montaggio completo.

Recomendamos que los fijadores sólo estén ajustados a mano hasta que se haya armado totalmente.

Wir empfehlen, alle Befestigungen zuerst nur fingerfest anzuziehen, bevor das Erzeugnis voll zusammengebaut ist.

**9**FA 5168  
80mm

4

FA 5094



4

FA 5175  
M6

4

FA 7084



4

MT 0007

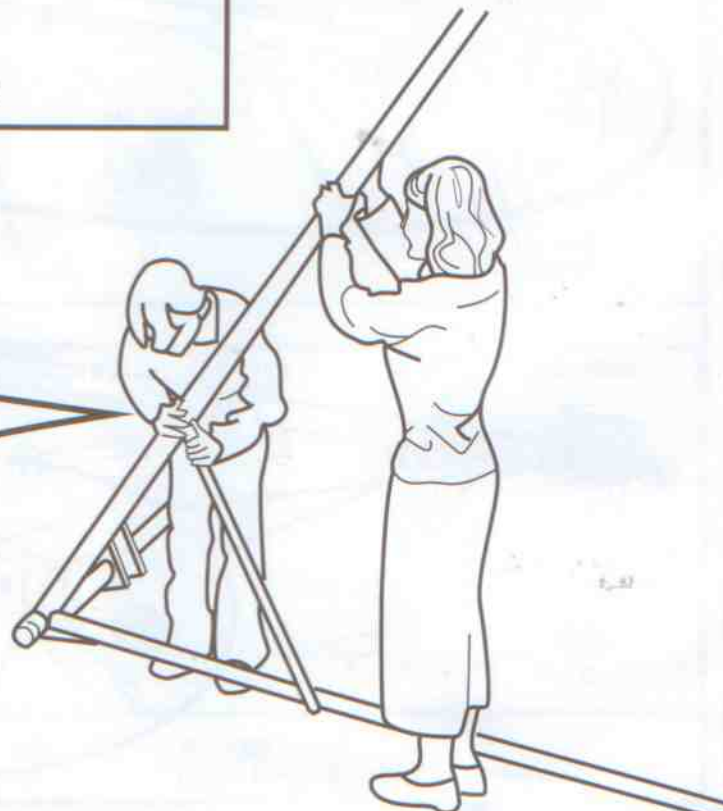
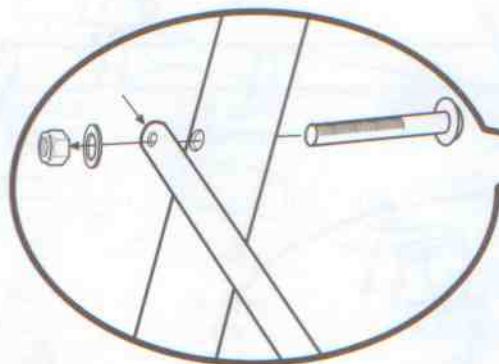
B  2

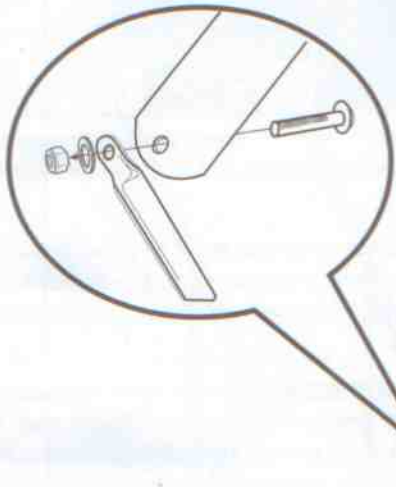
**10**

**CHECK ALL BOLTS ARE FULLY TIGHTENED**

Assurez-vous que les écrous et les boulons sont serrés au maximum.

Controllare che tutti i dadi e i bulloni siano ben serrati.

Compruebe que todas las tuercas y tornillos estén ajustados completamente.

Prüfen Sie, dass alle Muttern und Bolzen fest angezogen sind.

**11**

**Fitting Swing Accessories**

**Fixation de l'accessoire**

**Accesorio par fijar el columpio**

**Fissaggio del l'accessorio del l'altalena**

**Das Anbringen von Schaukelzubehör**

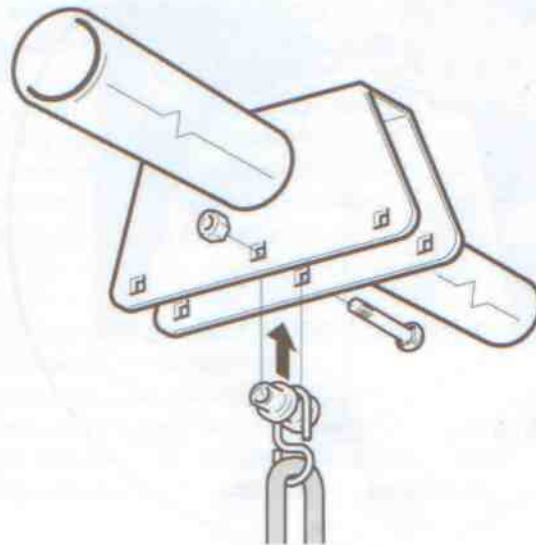
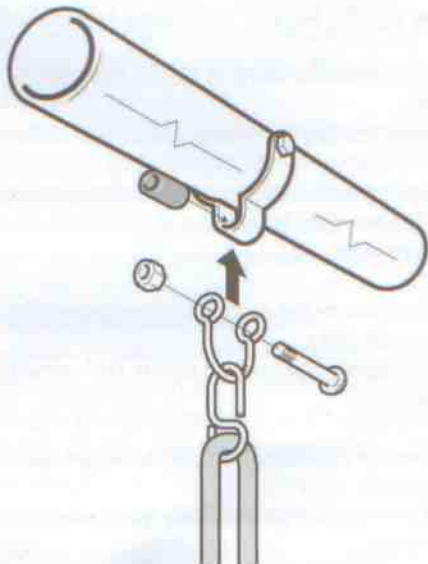

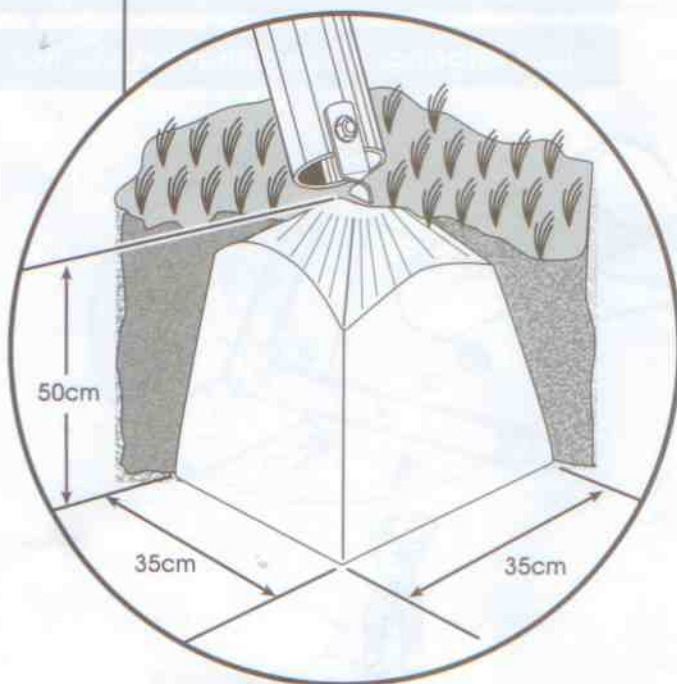
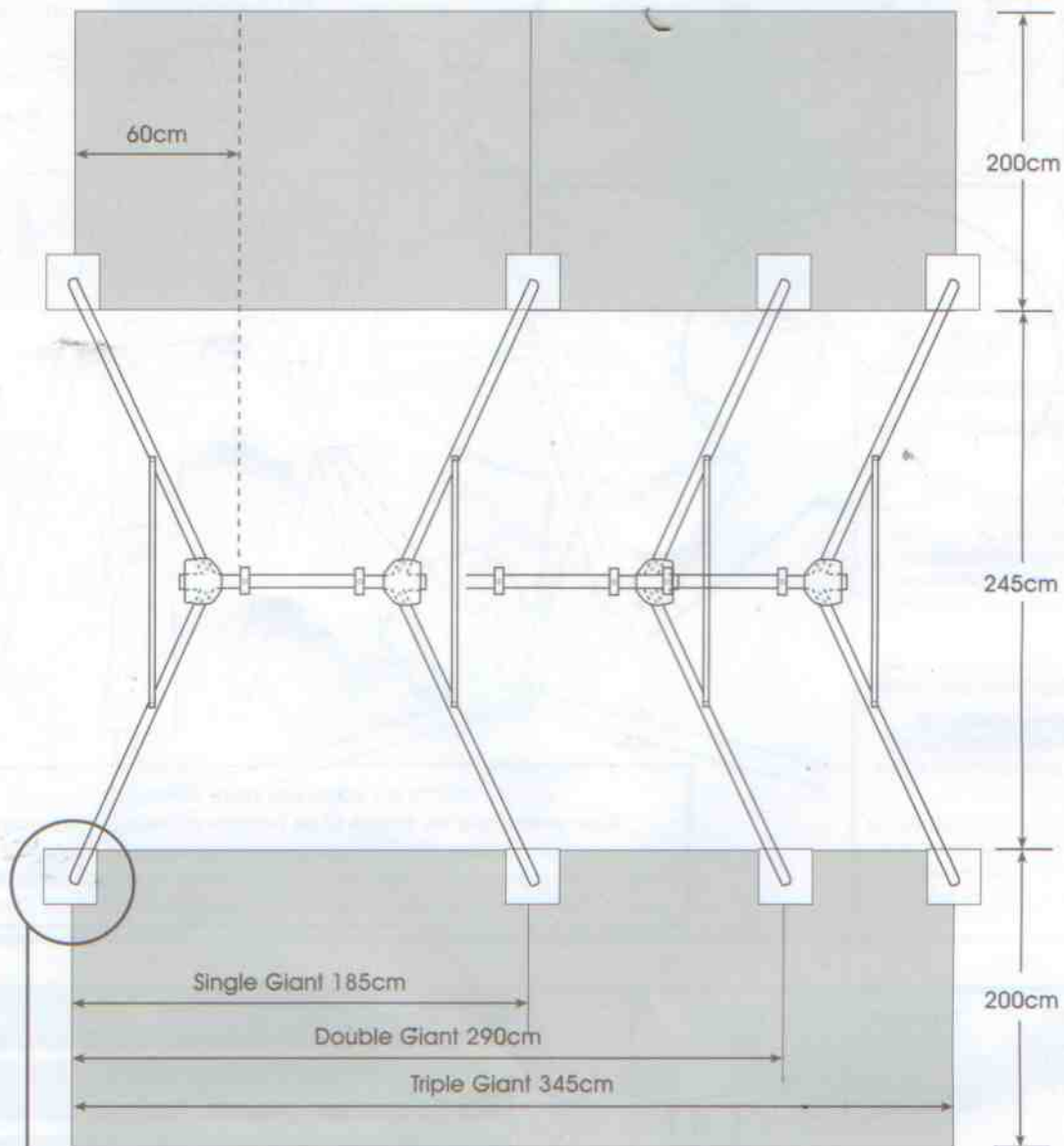

- Set the stakes in concrete (as shown).
- **Never set the legs of the frame in concrete.**
- Fixez les poteaux dans le béton comme cela est montré.
- **Ne fixez jamais les pieds du cadre dans le béton.**
- Fissare i paletti nel calcestruzzo come illustrato.
- **Non fissare mai le gambe dell'intelaiatura nel calcestruzzo.**
- Puede colocar las estacas sobre hormigún del modo indicado.
- **Pero nunca coloque las patas del armazón sobre hormigún.**
- Können Sie die Pfähle einzementieren, siehe Abbildung.
- **Die Rahmenstangen dürfen nicht einzementiert werden.**

**Recommended safe play area:**

The Safe Play Area refers to the zone extending 2m beyond the play set on all sides, including the space above the apparatus.

The Single Giant Swing requires a level ground surface of 645cm x 185cm for a Safe Play Area.

The Double Giant Swing requires a level ground surface of 645cm x 290cm for a Safe Play Area.

The Triple Giant Swing requires a level ground surface of 645cm x 345cm for a Safe Play Area.

Additional accessories may increase the size of the Safe Play Area.

The ground surface must be level. Installing your playset on sloping ground can cause it to lean or 'rack'. This puts additional stress on all the connections and joints and in time will cause them to fail.

The Safe Play Area must be free from all structures, landscaping, trees and branches, rocks, wires, sprinkler heads and other similar obstacles to safe play. Children can be seriously injured running or swinging into these obstacles.

**Aire de sécurité recommandée:**

L'aire de sécurité se réfère à la zone située dans un rayon de 2 m tout autour du jeu, y compris l'espace situé au-dessus de ce dernier.

L'ajout d'accessoires est susceptible d'étendre cette aire de sécurité.

La surface au sol doit être bien plane. Installé sur un terrain en pente, ce jeu pourra pencher ou s'endommager. Les composants seront alors soumis à des tensions plus importantes, ce qui risque de diminuer leur durée de vie.

L'aire de sécurité ne doit pas comporter de structures, aménagements paysagers, arbres et branches, pierres, câbles, têtes d'arrosage ou autres obstacles susceptibles d'empêcher les enfants de jouer en toute sécurité. Les enfants pourraient heurter ces obstacles en courant ou en se balançant et ainsi se blesser grièvement.

**Area di gioco sicura raccomandata:**

L'Area di giuoco sicura si riferisce alla zona che si estende per 2 m su tutti i lati oltre l'insieme da giuoco, incluso lo spazio al di sopra dell'apparato.

Gli accessori aggiuntivi possono estendere le dimensioni dell'Area di gioco sicura.

La superficie del terreno deve essere in pari. Installando l'insieme da giuoco sul terreno in pendenza, può inclinarsi o 'stirarsi'. Ciò sottoporrebbe tutti i componenti a sforzo addizionale, e potrebbe comprometterne la durata.

L'Area di gioco sicura deve essere libera da strutture, variazioni del terreno, alberi e rami, pietre, fili metallici, testine per annaffiare e tutto quanto esporrebbe a rischio la sicurezza del giuoco. Correndo contro questi ostacoli, o urtandovi durante l'oscillazione, i bambini potrebbero ferirsi seriamente.

**Área Segura de Juego recomendada:**

El Área Segura de Juego se refiere a la zona que se extiende hasta 2m desde los juegos todo alrededor, incluyendo el espacio encima del aparato. Accesorios adicionales pueden aumentar el tamaño del Área Segura de Juego.

La superficie del suelo debe ser uniforme. Si instala sus juegos sobre un terreno con declive, hará que se inclinen o se "arruinen". Esto coloca tensión adicional sobre todos los componentes y puede acortar su vida útil.

El Área Segura de Juego debe estar libre de todo tipo de estructuras, arquitectura paisajista, árboles y ramas, rocas, cables, boquillas de aspersores y cualquier otro elemento que pueda obstaculizar el juego seguro.

Los niños pueden herirse gravemente con estos obstáculos al correr o columpiarse.

**Empfohlene sichere Spielfläche:**

Die sichere Spielfläche erstreckt sich an allen Seiten 2 m über das Spielgerät hinaus, einschließlich Raum über dem Gerät. Zubehör kann die sichere Spielfläche erweitern. Der Boden muss eben sein.

Wenn Sie das Spielgerät auf einem Hang installieren, kann es sich lehnen oder verziehen.

Dadurch werden alle Teile zusätzlicher Last ausgesetzt, was zu verkürzter Lebensdauer führen kann. Im sicheren Spielraum darf sich nichts befinden, das sicheres Spielen behindern könnte wie z.B. Aufbauten, Gärten, Bäume oder Büsche, Steine, Draht, Rasensprinkler oder ähnliches. Wenn Kinder in solche Hindernisse hineinlaufen oder schaukeln, können sie sich schwer verletzen.

GB

Check your frame once a month for signs of wear or damage. Pay particular attention to the bolts (**fp** 5193) and the bushes (**fp** 5243). Replace if necessary.

Also, check the frame for any structural damage. Any dents or other impact damage can seriously weaken the frame. Any damaged parts should be replaced.

tp Customer Services: +44 (0) 1299 872804

tp Spare Parts: +44 (0) 1299 872803

F

Vérifiez le cadre une fois par mois pour repérer tout signe d'usure ou d'endommagement. Portez une attention toute particulière aux boulons (**fp** 5193) et aux bagues (**fp** 5243). Remplacez-les au besoin.

Vérifiez également que le cadre n'est pas endommagé dans sa structure. Les bosselures et autres signes d'impact peuvent gravement affaiblir le cadre. Vous devez remplacer toute pièce endommagée.

Service Clientèle tp: +44 (0) 1299 87 28 04 (langue anglaise)

Pièces Détachées tp: +44 (0) 1299 87 28 03 (langue anglaise)

I

Controllare l'intelaiatura una volta al mese per assicurarsi che non ci siano segni di logorio o di danneggiamento. Prestare particolare attenzione ai bulloni (**fp** 5193) e alle boccole (**fp** 5243). Cambiarli se necessario.

Controllare anche che l'intelaiatura non presenti danneggiamenti di tipo strutturale. Ogni ammaccatura od altro danneggiamento da impatto potrebbe indebolirla seriamente. Cambiare ogni parte danneggiata.

Servizio Clienti tp: +44 (0) 1299 87 28 04 (in inglese)

Pezzi di Ricambio tp: +44 (0) 1299 87 28 03 (in inglese)

E

Una vez al mes compruebe que su estructura no presente indicios de desgaste o daños. Especialmente, preste atención a los tornillos (**fp** 5193) y los bujes (**fp** 5243). Cámbielos si es necesario.

Asimismo, compruebe que la estructura no presente daños estructurales. Las abolladuras o cualquier otro tipo de daños por impacto pueden debilitar la estructura considerablemente. Toda pieza dañada deberá ser sustituida.

Servicios a los clientes de tp: +44 (0) 1299 87 28 04 (en inglés)

Piezas de recambio de tp: +44 (0) 1299 87 28 03 (en inglés)

D

Überprüfen Sie den Rahmen einmal pro Monat auf Verschleiß und Beschädigung. Beachten Sie dabei besonders die Bolzen (**fp** 5193) und Buchsen (**fp** 5243). Bei Bedarf sind diese auszutauschen.

Überprüfen Sie den Rahmen auch auf konstruktiven Schaden. Beulen und ähnliche Stoßschäden können zu ernsthaften Schwächen im Rahmen führen. Beschädigte Teile sind auszutauschen.

tp Kundendienst: +44 (0) 1299 87 28 04 (nur Englisch)

tp Ersatzteildienst: +44 (0) 1299 87 28 03 (nur Englisch)

**Register your new TP product on-line now at**  
**[www.tptoys.com/productregistration](http://www.tptoys.com/productregistration)**

For a chance to win £200 of TP products in our next quarterly on-line guarantee registration draw.  
Immediate access to TP products updates and offers.

**TERMS AND CONDITIONS**

Each quarter one prize of £200 worth of TP products will be won. Your on-line purchase registration will be entered in the next available quarterly draw only. Postal registrations will not be included. No cash alternative is available in any circumstances.

Open to all TP purchasers who are aged over 18 years who register their new TP product on-line except employees of TP Activity Toys. The winners will be notified in writing within four weeks of the draw. No correspondence will be entered into. A list of winners is available on request 6 weeks after every draw by contacting TP at the address given below. TP Activity Toys reserve the right to alter, amend, or otherwise change the terms of the Prize Draws in the interest of the consumer without prior notification. This promotion is being run by TP Activity Toys (Tube Plastics Ltd), Severn Road, Stourport on Severn, Worcestershire DY13 9EX

Alternatively, complete the form opposite and place in an envelope addressed to TP Activity Toys, Severn Road, Stourport on Severn, DY13 9EX England. Please remember a stamp. Remember however, that you must register on-line to enter our prize draw.

**Data Protection**

TP will not pass your personal information to anyone else. If you would like to receive information on TP please tick the appropriate box.

**Product Registration Form**

Mr.  Mrs  Miss  Ms

First name: ..... Surname: .....

E-mail: .....

Address: .....

Postcode: .....

Tel: .....

Product(s) purchased ..... TP Product no. No of children: .....

TP ..... Dates of birth: .....

TP .....  
TP .....  
TP .....  
TP .....  
TP .....



# Lifetime Guarantee

**Thank you** for purchasing one of our quality swinging frames. The product carries a **Lifetime Guarantee** against rust causing failure on the galvanised steel frame.



Freedom to play

TP Activity Toys guarantees to you, the original retail purchaser, that for your children's lifetime of play, rust will not cause the product to fail structurally. (Failure is defined as rusting from the inside through to the outside ie perforation.) In the unlikely event of such rusting occurring **tp** will either supply replacement parts of the affected area, or replace the toy if the parts are no longer available.

Galvanised products are very tough but they may require maintenance from time to time (as detailed in the maintenance notes at the front of this handbook.) Regular inspections are important. Any surface rust, staining etc should be treated in accordance with these instructions and are not covered by the **Lifetime Guarantee**.

The Guarantee does not apply to any part if damage has been caused by abuse, vandalism, misuse, accident or non-maintenance or if the original purchaser resides outside the United Kingdom and Republic of Ireland. For purchasers living outside the United Kingdom or Republic of Ireland, all components are covered by a one year guarantee.

To be covered by this **Guarantee** it is essential that you complete and return one **Guarantee Registration**,

listing all products purchased. As an additional bonus you will then automatically be entered into the **Quarterly Prize Draw**.

This helps us to monitor and maintain our performance as market leaders in the design and manufacture of outdoor play and associated products. It also helps us to communicate quickly with you should the need arise and to keep you up to date with the developments in our range.

\*This guarantee does not affect your legal rights.

## Claim Procedure

Should a claim be necessary please write to our Customer Services Department, TP Activity Toys., Stourport-on-Severn, Worcestershire, DY13 9EX, England.

We would require the following information and we recommend that you complete some of these details now:

**Your name, address and daytime/evening telephone number.**

**Product Name.**

**Guarantee Number.**

**Date of Purchase.**

**Where Purchased.**

**Original Till Receipt.**

**Identification of the Affected Part(s) - Photographs preferable.**

Please do not send products or parts at this stage as this may not be necessary.

**This Guarantee Number is:**

**TP**

732021051101

Designed in the UK by **TP Activity Toys** (Tube Plastics Ltd), Severn Road, Stourport on Severn, Worcestershire, DY13 9EX, England.  
Made in England.

Customer Service:

Email: [customerservices@tp toys.com](mailto:customerservices@tp toys.com)

Website: [www.tptoys.com](http://www.tptoys.com)



Spare Parts +44 (0) 1299 872803

Technical Helpline +44 (0) 1299 872804

TP Part No: 8821 Issue: 8 09 09



**Register your new TP product on-line now at**  
[www.tptoys.com/productregistration](http://www.tptoys.com/productregistration)



Freedom to play

- For a chance to win £200 of TP products in our next quarterly on-line product registration draw.
- Immediate access to TP products updates and offers.

Full terms and conditions overleaf.

**This Guarantee Number is:**

**TP**